



Mathematical Model of the Transmission Dynamics of Corona Virus Disease (COVID-19) and Its Control

Atokolo William^{1*}, Omale David¹, Bashir Sezuo Tenuche¹,
Olayemi Kehinde Samuel¹, Daniel Musa Alih¹ and Akpa Johnson¹

¹Department of Mathematical Sciences, Kogi State University, Anyigba, Kogi State, Nigeria.

Authors' contributions

The work was carried out in collaboration among all the authors. Author AW formulated the model. Author OKS performed the analyses. Author BST managed the literature searches. Authors DMA and AJ managed the model simulation and author OD supervised the work. All the authors read and approve the final manuscript.

Article Information

DOI: 10.9734/ARJOM/2020/v16i1130244

Editor(s):

- (1) Dr. Nikolaos D. Bagis, Aristotle University of Thessaloniki, Greece.
- (2) Dr. Krasimir Yankov Yordzhev, South-West University, Bulgaria.
- (3) Dr. Andrej V. Plotnikov, Odessa State Academy of Civil Engineering and Architecture, Ukraine.

Reviewers:

- (1) Sarvesh Tanwar, Amity University, Noida.
- (2) Sri Ram Chandra Polisetty, Godavari Institute of Engineering and Technology (Autonomous), India.
- (3) Charugundla Nagaratnamaiiah, Vasireddy Venkatadri Institute of Technology, India.
- (4) Ali J. Abboud, University of Diyala, Iraq.
- (5) Mohamed Ibrahim Abbas Ali, Alexandria University, Egypt.

Complete Peer review History: <http://www.sdiarticle4.com/review-history/63754>

Original Research Article

Received: 20 November 2020

Accepted: 15 December 2020

Published: 13 January 2021

Abstract

This work is aimed at formulating a mathematical model for the transmission dynamics and control of corona virus disease in a population. The Disease Free Equilibrium state of the model was determined and shown to be locally asymptotically stable. The Endemic Equilibrium state of the model was also established and proved to be locally asymptotically stable using the trace and determinant method, after which we determined the basic reproduction number (R_0) of the model using the next generation method. When ($R_0 < 1$), the disease is wiped out of a population, but if ($R_0 > 1$), the disease invades such population. Local sensitivity analysis result shows that the rate at which the exposed are quarantined (θ), the rate at which the infected are isolated (ϕ), the rate at which the quarantined are isolated (η), and the treatment rate (γ) should be targeted by the control intervention strategies as an increase in the

*Corresponding author: E-mail: williamsatokolo@gmail.com;

values of these parameters (θ, ϕ, η and γ) will reduce the basic reproduction number (R_0) of the COVID-19 and as such will eliminate the disease from the population with time. Numerical simulation of the model shows that the disease will be eradicated with time when enlightenment control measure for the susceptible individuals to observe social distance, frequent use of hand sanitizers, covering of mouth when coughing or sneezing are properly observed. Moreso, increasing the rates at which the suspected and confirmed cases of COVID-19 are quarantined and isolated respectively reduce the spread of the global pandemic.

Keywords: Corona; virus; model; quarantine; isolation; treatment.

1 Introduction

Corona virus (COVID-19) is an ongoing pandemic disease caused by severe acute respiratory syndrome Corona virus 2 (SARS-COV2) [1]. The disease was identified in Wuhan, China in December 2019 [2] and was declared to be a public health emergency of international concern on the 30th January, 2020 and was also recognized as a pandemic by the World Health Organization on the 11th March, 2020 [3,4]. As of 14th April, 2020 more than 1.94 million cases [5] of Corona virus have been reported in 210 countries and territories [6] resulting in more than 121,000 deaths with more than 465,000 recoveries [5]. Death and recoveries rates vary significantly between countries [7].

The symptoms include fever; cough and shortness of breath [8]. Complications may include pneumonia and acute respiratory distress syndrome [9]. The time from exposure to onset of symptoms is between 2 to 14 days [10]. They are no vaccine presently and they are no specific antivirus medications approved for COVID-19, but development efforts are underway. Drinking fluids, resting, oxygen therapy intravenous fluids and breathing supports may help to alleviate symptoms depending on the severity [11]. The primary treatment is symptomatic and through supportive therapy [9,11].

The disease is transmitted primarily during close contact and by small droplets produced during coughing, sneezing or talking [2] with close contact being within 1 to 2 meters which is equivalent to 3 to 6 feet [12]. Both sputum and saliva can carry large virus loads [2,12].

Research shows that an uncovered cough can lead to droplet travelling up to 4.5 meters to 11.4 meters [2]. Respiratory droplets may also be produced during breathing out, talking, though the virus is not generally airborne [2], the droplets can land on the mouths or noses of people who are nearby or possibly be inhaling into the lungs [12]. The virus can also be transmitted when one touches a contaminated surface, including skin and then touches the eyes, nose or mouth [13].

Diagnosis is on the basis of Symptoms, though confirmation is ultimately by reverse transcription-polymerase chain reaction (rRT-PCR) of infected secretions or Computed Tomography (CT) imaging [14,15]. The test using (rRT-PCR) can be done on respiratory or blood samples and results are generally available within a few hours to days. In the U.S, a serological test which detects antibodies are developed by cells and it is approved for emergency use by certified laboratories only [16]. Preventive measures include hand washing covering one's mouth when coughing, maintaining distance from other people, and self-isolation for people who are suspected to have been infected with the virus [12]. Authorities worldwide have responded by implementing travel restrictions, quarantines, curfews and stay-at-home orders which has led to severe global social-economic disruption, cancellation of sporting, religious, political and cultural events [17].

A number of modelling researches have already been performed for the epidemic. Wu et al. [18] presented a Susceptible, Exposed, Infected and Removed (SEIR) model to describe the transmission dynamics of the corona virus; they predicted a global spread of the virus. Read et al. [19] estimated a value of (3.1) for the basic reproduction number of COVID-19 based on data fitting of a SEIR model which epidemiologically shows that the disease will spread globally. Tang et al. [20] also proposed a deterministic model for corona virus with a high basic reproduction number of (6.47) which implies that the disease will invade the population. Gao et al. [21] developed a model that incorporates a learning algorithm to analyze the infectivity of the novel corona virus and predicts its potential host, results show that bats and minks may be the two animal hosts of the virus.

Most of the existing work on corona virus did not consider the role of control measures in the spread of COVID-19 as highlighted above. In this present work, we present the role of enlightenment control measure for the susceptible individuals to observe social distance, the need to use hand sanitizers or frequent washing of hands, covering of mouth when talking, coughing or sneezing in public and lastly the isolation of infected human on the spread and control of corona virus in a population.

The specific objectives of the work are to develop a mathematical model for the transmission dynamics of COVID-19 with control measures, to determine the basic reproduction number of the pandemic disease, to perform local stability analysis of the model and to conduct sensitivity analysis on the model parameters to determine which of the parameters can be targeted by the control intervention strategies.

This study is significant as humanity will always entertain contributions for prevention, control and even the eradication of the COVID-19 pandemic. The research will be appreciated in the medical world; policy makers can also use the acquired knowledge from this research on the need to always quarantine suspected cases of COVID-19, isolate the confirmed cases, observation of social distance, frequent washing of hands or the use of hand sanitizers, covering of mouth when coughing or sneezing in public by the Susceptible individuals and the provision of supportive treatment to the infected individuals. The general public will through this research see the need to observe preventive measures on the need to stay safe as prevention is better than cure.

2 Model Formulation and Procedures

In modelling the spread of disease (COVID'19) pandemic, we assume the following:

- i. The model incorporates a net inflow of individuals into the susceptible population. This parameter comprises of new births, immigration and emigration.
- ii. All classes of the population die naturally.
- iii. Disease induced death is considered in the model.
- iv. Infected individuals can recover naturally, though the rate is assumed to be minimal.
- v. The Recovered has permanent immunity for re-infection.
- vi. Every individual taken for treatment recover at a high rate, that is to say the treatment is considered to be effective.
- vii. The population is divided into the Susceptible class (S), the Exposed class (E), Quarantined class (Q), Isolated class (J), the Infected class (I), the Infected but treated class (I_T), and the Recovered class (R).

2.1 Model formulation

The Susceptible population (S): The Susceptible population is recruited at the level of (Λ), decreases at the rate by which they are exposed to the virus at a contact rate of (α). This rate can be reduced by a factor

$(1 - \alpha)$, where (x) is a control parameters which represents the enlightenment control measure for the Susceptible individuals to observe social distance (that is to say, to avoid close contact), washing of hands always or the use of hand sanitizers, covering of mouth when talking, coughing and sneezing. These strategies are assumed to be observed at the same rate of (x) . The susceptible population (S) decreases finally at the rate of (μ) which represents natural death of the individuals.

The Exposed population (E) : The Exposed population, increases by the progression of individuals from the susceptible class at the rate of $(1 - x)$. If $x = 0$, this implies that the susceptible individuals do not observe the necessary control measures stated or the campaign has no influence on the susceptible population. If $x = 1$ the Susceptible individuals observe the necessary control measures and as such the campaign has influence on the susceptible population. The Exposed population reduces as a result of the progression of individuals into the infected class at the rate of (β) , the population also decreases because individuals with suspected cases of COVID'19, which are assumed to be quarantined at the rate of $\theta(1 + y)$, where (y) is a control parameter that represents the enlightenment campaign measure for the exposed individuals to be quarantined for some times. If $y = 0$ the campaign has no influence on the Exposed population, whereas, if $y = 1$, the campaign has influence on the Exposed class. The class finally reduces due to natural death rate at the rate of (μ) .

The Quarantined population (Q): The Quarantined population increases due to the progression of the Exposed individuals (Those suspected to have COVID'19 but do not show the symptoms) to the Quarantined class at the rate of $\theta(1 + y)$, the class reduces due to the progression of confirmed cases of COVID'19 into the Isolated class (J) at the rate of (η) . The population of the quarantined class reduces finally due to natural death at the rate (μ) .

The Isolated class (J): The Isolated class is increased due to the progression of those who are quarantined and after sometimes they become symptomatic (showing symptoms of the disease) which are now isolated at the rate of (η) . The population also increases due to the progression of the infected at the rate of $\emptyset(1 + z)$ where (z) is a control parameter that represents the enlightenment campaign measure for the infected population to be isolated immediately for treatment. If $(z = 0)$, the campaign measure has no influence on the infected population, whereas if $(z = 1)$ the campaign has influence on the population of the infected class. The population of the isolated class reduces due to the rate at which individuals in that class are taken for treatment at the rate of (γ) also the class is assumed to be reduced due to natural recovery at the rate of (ρ) . This is possible because we assume that individuals infected can naturally recover at a minimal rate of (ρ) . The population finally reduces due to disease induced death and natural death at the rate of (σ) and (μ) respectively.

The Infected class (I): The Infected class is increased due to the progression of individuals from the Exposed class who are infected at the rate of (β) , the population reduces at the level of $\emptyset(1 + z)$, this represents the rate at which the infected are isolated. The population also reduces due to minimal natural recovery rate of (λ) . The class finally decreases due to disease induced death and natural death at the rates of (σ) and (μ) respectively.

The Infected but treated class (I_T): The Infected but treated class is increased due to the progression of individuals from the isolated class who are taken for treatment at the rate of (λ) . The population reduces due to the rate by which treated individuals recovers at the rate of (ω) . This population reduces finally due to disease induced death and natural death at the rate of (σ) and (μ) respectively.

The Recovered population (R): The Recovered population increases due to the progression of individuals from the infected and isolated classes that recover naturally at the minimal rates of (λ) and (ρ) respectively. The class also increases due to treatment at the rate of (ω) . The Recovered population reduces due to natural death at the rate of (μ) .

2.2 Model flow diagram for the transmission dynamics and control of COVID'19

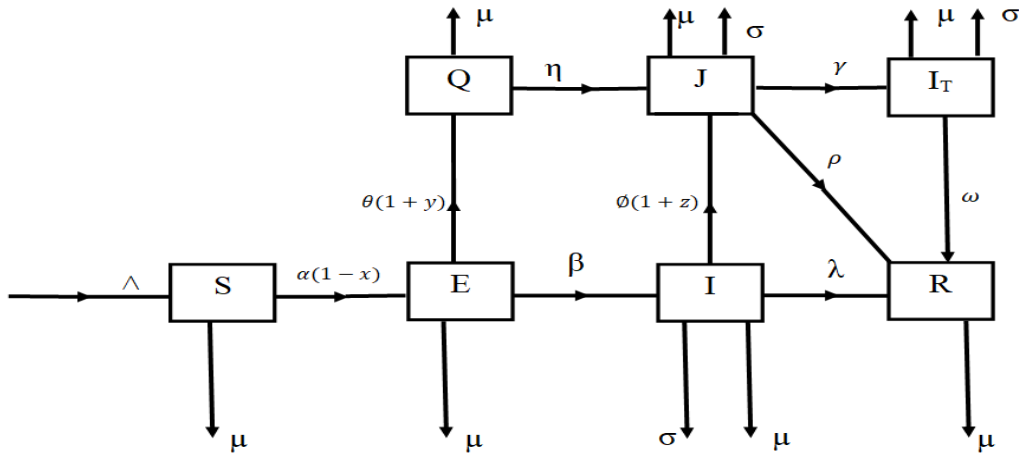

Fig. 1. Model flow diagram for COVID'19

2.3 Mathematical model for the transmission and control of COVID-19

The mathematical model that incorporates the above assumptions is given as:

$$\left. \begin{aligned}
 \frac{dS}{dt} &= \Lambda - \alpha(1-x)S - \mu S \\
 \frac{dE}{dt} &= \alpha(1-x)S - [\theta(1+y) + \beta + \mu]E \\
 \frac{dQ}{dt} &= \theta(1+y)E - (\eta + \mu)Q \\
 \frac{dJ}{dt} &= \eta Q + \phi(1+z)I - (\mu + \sigma + r + \rho)J \\
 \frac{dI}{dt} &= \beta E - [\phi(1+z) + \lambda + \sigma + \mu]I \\
 \frac{dI_T}{dt} &= \gamma J - (\omega + \mu + \sigma)I_T \\
 \frac{dR}{dt} &= \lambda I + \rho J + \omega I_T - \mu R
 \end{aligned} \right\} \quad (1)$$

Where $\alpha = \frac{\alpha_1 E + \alpha_2 Q + \alpha_3 J + \alpha_4 I + \alpha_5 I_T}{N}$

and $0 \leq x \leq 1, 0 \leq y \leq 1, 0 \leq z \leq 1$

where x, y, z , are control parameters

2.4 Model variables and parameters description

Table 1. Model variables & description

S/N	VARIABLES	DESCRIPTION
1.	S	Susceptible Human
2.	E	Exposed Human
3.	Q	Quarantined Human
4.	J	Isolated Human
5.	I	Infected Human
6.	I _T	Infected but treated Human
7.	R	Recovered Human

Table 2. Model parameter and description

S/N	VARIABLES	DESCRIPTION
1	\wedge	Recruitment rate
2	α	Force of infection
3	θ	Rate at which the exposed are quarantine
4	η	Rate at which the quarantined are isolated
5	β	Rate at which the exposed are infected
6	\emptyset	Rate at which the infected are isolated
7	γ	Treatment rate
8	ρ	Natural recovery rate of the isolated
9	λ	Natural recovery rate of the infected
10	ω	Recovery rate due to treatment
11	σ	Disease induced death rate
12	μ	Natural death rate
13	x	Enlightenment control measures for the susceptible individuals to observe social distance, washing of hands, covering of mouth when talking, coughing and sneezing
14	y	Enlightenment control measure for the exposed to be quarantined
15	Z	Enlightenment control measure for the infected to be isolated

3 Model Analysis

3.1 Disease free equilibrium (DFE)

At the Disease Free Equilibrium (DFE), there is no COVID-19 infection and as such

$$E = Q = J = I = I_T = R = 0$$

Also at equilibrium:

$$\frac{dS}{dt} = \frac{dE}{dt} = \frac{dQ}{dt} = \frac{dJ}{dt} = \frac{dI}{dt} = \frac{dI_T}{dt} = \frac{dR}{dt} = 0$$

The DFE state is represented by:

$$[S^0 \ E^0 \ Q^0 \ J^0 \ I^0 \ I_T^0 \ R^0]$$

Which is represented by:-

$$\varepsilon_0 = \left[\frac{\wedge}{\mu}, 0, 0, 0, 0, 0, 0 \right] \tag{2}$$

Proof :

From model (1), we have from the susceptible equation that

$$0 = \wedge - \alpha(1 - x)S^0 - \mu S^0$$

But the force of Infection

$$\alpha = \frac{\alpha_1 E + \alpha_2 Q + \alpha_3 J + \alpha_4 I + \alpha_5 I_T}{N} = 0$$

This is obvious because $E = Q = J = I = I_T = R = 0$

$$0 = \wedge - \mu S^0$$

$$\mu S^0 = \wedge$$

$$\Rightarrow S^0 = \frac{\wedge}{\mu}$$

Since there is no infection at DFE state, therefore we can state categorically that $E^0 = Q^0 = J^0 = I^0 = I_T^0 = R^0 = 0$

3.2 Endemic disease equilibrium (EE)

At the endemic disease equilibrium, infection exists and as such we let:

$$S = S^*, E = E^*, Q = Q^*, J = J^*, I = I^*, I_T = I_T^* \text{ and } R = R^*$$

Also at equilibrium,

$$\frac{dS}{dt} = \frac{dE}{dt} = \frac{dQ}{dt} = \frac{dJ}{dt} = \frac{dI}{dt} = \frac{dI_T}{dt} = \frac{dR}{dt} = 0$$

The EE is represented by $[S^*, E^*, Q^*, J^*, I^*, I_T^*, R^*]$ which is given by:

$$\varepsilon_1 = \left\{ \begin{array}{l} \frac{\alpha(1-x)}{[\theta(1+y)+\beta+\mu]E^*}, \frac{\beta}{[\emptyset(1+z)+\lambda+\sigma+\mu]}, \frac{\theta(1+y)E^*}{(\eta+\mu)}, \frac{(\omega+\mu+\sigma)I_T^*}{\gamma}, \\ \frac{(\eta+\mu)(\mu+\sigma+\gamma+\rho)(\omega+\mu+\sigma)I_T^* - \gamma\eta\theta(1+y)E^*}{\emptyset\gamma(\eta+\mu)(1+z)}, \frac{(\lambda+\mu\gamma\lambda)I^*}{[\omega\gamma\mu+\rho\mu\omega(\omega+\mu+\sigma)]}, \frac{\gamma\lambda I^* + [\rho(\omega+\mu+\sigma) + \gamma\omega]I_T^*}{\gamma\mu} \end{array} \right\} \quad (3)$$

Proof:

From the second equation of model (1)

$$0 = \alpha(1-x)S^* - [\theta(1+y) + \beta + \mu]E^*$$

$$\therefore S^* = \frac{\alpha(1-x)}{[\theta(1+y) + \beta + \mu]E^*} \quad (4)$$

Also from the third equation of model (1) we have that

$$(\eta + \mu)Q^* = \theta + (1 + y)E^*$$

$$\therefore Q^* = \frac{\theta(1+y)E^*}{(\eta+\mu)} \quad (5)$$

Also from the fifth equation of model (1) we have that

$$[\emptyset(1+z) + \lambda + \sigma + \mu]I^* = \beta E^*$$

$$\therefore E^* = \frac{\beta}{[\emptyset(1+z)+\lambda+\sigma+\mu]I^*} \quad (6)$$

From the sixth equation of model 1 we have that

$$(\omega + \mu + \sigma)I_T^* = \gamma J^*$$

$$\therefore J^* = \frac{(\omega + \mu + \sigma)I_T^*}{\gamma} \tag{7}$$

From the fourth equation of model (1) we have that

$$\begin{aligned} (\mu + \sigma + \gamma + \rho)J^* &= \eta Q^* + \phi(1 + z)I^* \\ \phi(1 + z)I^* &= (\mu + \sigma + \gamma + \rho)J^* - \eta Q^* \\ I^* &= \frac{(\mu + \sigma + \gamma + \rho)J^* - \eta Q^*}{\phi(1 + z)} \end{aligned} \tag{8}$$

Substituting equation (5) and (7) into (8) we have that:

$$I^* = \frac{(\eta + \mu)(\mu + \sigma + \gamma + \rho)(\omega + \mu + \sigma)I_T^* - \gamma\eta\theta(1 + y)E^*}{\phi\gamma(\eta + \mu)(1 + z)} \tag{9}$$

From the last equation of model (1) we have that

$$\begin{aligned} \mu R^* &= \lambda I^* + \rho J^* + \omega I_T^* \\ \therefore R^* &= \frac{\lambda I^* + \rho J^* + \omega I_T^*}{\mu} \end{aligned} \tag{10}$$

Substituting equation (7) into (10) we have

$$R^* = \frac{\gamma\lambda I^* + [\rho(\omega + \mu + \sigma) + \gamma\omega]I_T^*}{\gamma\mu} \tag{11}$$

Also from the last equation of model (1), we have that;

$$\mu R^* = \lambda I^* + \rho J^* + \omega I_T^*$$

Where $\omega I_T^* = \mu R^* - \lambda I^* - \rho J^*$

$$I_T^* = \frac{\mu R^* - \lambda I^* - \rho J^*}{\omega} \tag{12}$$

Substituting equation (7) and (11) into (12) we have that

$$\begin{aligned} [I_T^* \gamma\mu + \rho\mu(\omega + \mu + \sigma)I_T^*]\omega &= (\lambda - \mu\gamma\lambda)I^* \\ I_T^* &= \frac{(\lambda - \mu\gamma\lambda)I^*}{[\gamma\mu + \rho\mu(\omega + \mu + \sigma)]\omega} \end{aligned} \tag{13}$$

The presence of E^* , I^* and I_T^* in the expression for ε_1 which is represented by equation (7) shows that the disease is actually present in the population.

3.3 Basic reproduction number (R_0) of the covid-19 model

Definition: It is defined as the number of secondary infection produced by infected persons during his/her life time, in a complete susceptible population [22]. The basic reproduction number is mathematical expressed as:

$$R_0 = \gamma(FV^{-1})$$

Where:

$$F = \frac{\partial Fi}{\partial xj}(x_0) \text{ and } \frac{\partial Vi}{\partial xj}(x_0)$$

Such that

$$F_i = \begin{bmatrix} \frac{\alpha(1-x)S^0}{N} \\ 0 \\ 0 \\ 0 \end{bmatrix} \text{ and } V_i = \begin{pmatrix} [(1+y)+\beta+\mu]E \\ (\eta+\mu)Q-\theta(1+y)E \\ (\mu+\sigma+\gamma+\ell)J-\eta Q-\phi(1+z)I \\ [\phi(1+z)+\lambda+\sigma+\mu]I-\beta E \\ (\omega+\mu+\sigma)I_T-\gamma J \end{pmatrix} \text{ where:}$$

$$\alpha = \frac{\alpha_1 E + \alpha_2 Q + \alpha_3 J + \alpha_4 I + \alpha_5 I_T}{N}$$

$$F = \begin{pmatrix} \frac{\alpha_1(1-x)S^0}{N} & \frac{\alpha_2(1-x)S^0}{N} & \frac{\alpha_3(1-x)S^0}{N} & \frac{\alpha_4(1-x)S^0}{N} & \frac{\alpha_5(1-x)S^0}{N} \\ 0 & 0 & 0 & 0 & 0 \\ 0 & 0 & 0 & 0 & 0 \\ 0 & 0 & 0 & 0 & 0 \\ 0 & 0 & 0 & 0 & 0 \end{pmatrix}$$

Also

$$V = \begin{pmatrix} [(1+y)+\beta+\mu] & 0 & 0 & 0 & 0 \\ -\phi(1+y) & (\eta+\mu) & 0 & 0 & 0 \\ 0 & -\eta & (\mu+\sigma+\gamma+\ell)-\phi(1+z) & 0 & 0 \\ -\beta & 0 & 0 & [\phi(1+z)+\lambda+\sigma+\mu] & 0 \\ 0 & 0 & -\gamma & 0 & (\omega+\mu+\sigma) \end{pmatrix}$$

Using maple 2015 software and find the inverse of V we let $a = [\theta(1+y)+\beta+\mu]$, $b = -\theta(1+y)$, $c = (\eta+\mu)$, $d = (\mu+\sigma+\gamma+\ell)$, $e = -\theta(1+z)$, $f = [\phi(1+z)+\lambda+\sigma+\mu]$, $g(\omega+\mu+\sigma)$

$$V^{-1} = \begin{pmatrix} \frac{1}{a} & 0 & 0 & 0 & 0, \\ -\frac{b}{ac} & \frac{1}{c} & 0 & 0 & 0 \\ -\frac{bf\eta+ce\beta}{dcaf} & \frac{\eta}{cd} & \frac{1}{d} & \frac{-e}{fd} & 0 \\ \frac{\beta}{af} & 0 & 0 & \frac{1}{f} & 0, \\ -\frac{\gamma(bf\eta+ce\beta)}{dcaf} & \frac{\gamma}{d} & \frac{\gamma}{dg} & \frac{-\gamma}{dfg} & \frac{1}{g} \end{pmatrix}$$

Also using maple 2015 software

$$(FV^{-1}) = \begin{bmatrix} k_1 & k_2 & k_3 & k_4 & k_5 \\ 0 & 0 & 0 & 0 & 0 \\ 0 & 0 & 0 & 0 & 0 \\ 0 & 0 & 0 & 0 & 0 \\ 0 & 0 & 0 & 0 & 0 \end{bmatrix} \quad \text{Where}$$

$$k_1 = \left[\alpha_1 - \frac{\alpha_2 b}{c} + \frac{\alpha_3 (ce\beta - bf\eta)}{cdf} + \frac{\alpha_4 \beta}{f} + \frac{\alpha_5 (\gamma ce\beta - \gamma bf\eta)}{cdfg} \right] \frac{(1-x)S^0}{aN}$$

$$k_2 = \left[\alpha_2 + \frac{\alpha_3 \eta}{d} + \frac{\alpha_5 \gamma \eta}{dg} \right] \frac{(1-x)S^0}{cN}$$

$$k_3 = \left[\alpha_3 + \frac{\alpha_5 \gamma}{g} \right] \frac{(1-x)S^0}{dN}$$

$$k_4 = \left[\alpha_4 - \frac{\alpha_3 e}{d} - \frac{\alpha_5 \gamma e}{dg} \right] \frac{(1-x)S^0}{fN}$$

$$k_5 = \frac{\alpha_5 (1-x)S^0}{gN}$$

Now finding the Eigen values of (FV^{-1}) Using the same maple software gives:

$$\begin{bmatrix} 0 \\ 0 \\ 0 \\ 0 \\ k_1 \end{bmatrix}$$

The dominant Eigen value is seen to be $k_1 = \ell(FV)^{-1} = R_0$

$$k_1 = \left[\alpha_1 - \frac{\alpha_2 b}{c} + \frac{\alpha_3 (ce\beta - bf\eta)}{cdf} + \frac{\alpha_4 \beta}{f} + \frac{\alpha_5 (\gamma ce\beta - \gamma bf\eta)}{cdfg} \right] \frac{(1-x)S^0}{aN}$$

Substituting now expressions for a, b, c, d, e, f, g stated earlier, where $S^0 = \frac{\Lambda}{\mu}, N = \frac{\Lambda}{\mu}$ we now have

that:

$$R_0 = \left\{ \begin{array}{l} \alpha_1 + \frac{\alpha_2 \theta(1+y)}{(\eta+\mu)} + \frac{\alpha_3 \eta [\theta(1+y)(\theta(1+z)+\lambda+\sigma+\mu) - \phi \beta (\eta+\mu)(1+z)]}{(\eta+\mu)(\mu+\sigma+\gamma+\ell)(\phi(1+z)+\lambda+\sigma+\mu)} - \\ \frac{\alpha_4 (\phi(1+y))}{(\phi(1+z)+\lambda+\sigma+\mu)} + \frac{\alpha_5 [\gamma \theta \eta (1+y)(\phi(1+z)+\lambda+\sigma+\mu) - \gamma \phi \beta (\eta+\mu)(1+z)]}{(\eta+\mu)(\mu+\sigma+\gamma+\ell)(\phi(1+z)+\lambda+\sigma+\mu)(\omega+\mu+\sigma)} \end{array} \right\} \frac{(1-x)}{\theta(1+y)+\beta+\mu} \quad (14)$$

Equation (14) is therefore the basic reproduction number for the spread of corona virus in a population. The value of this quantity (R_0) determines whether the disease will be invaded in a population or the disease will be eliminated from a population.

If $R_0 < 1$ this epidemiologically implies that the disease will be reduced or eliminated from the population. Similarly, if $R_0 > 1$, the disease invades the population. Therefore to control the COVID-19, effort should be targeted toward the reduction of this quantity (R_0) to be less than 1. This can be achieved by increasing or decreasing values of same sensitive parameters that form the (R_0) which will be discussed in section (4.0).

3.4 Local stability analysis of the disease free equilibrium state of the model

We investigate the local stability of the disease free equilibrium point of the model. We first linearize the model by computing its Jacobian matrix (J) at the disease free equilibrium point(ϵ_0).

From the model (1), the Jacobian matrix (J) is expressed as:

$$= \begin{vmatrix} -[\alpha(1-x)+\mu] & 0 & 0 & 0 & 0 & 0 & 0 & 0 \\ \alpha(1-x) & -[\theta(1+y)+\beta+\mu] & 0 & 0 & 0 & 0 & 0 & 0 \\ 0 & \theta(1+y) & -(\eta+\mu) & 0 & 0 & 0 & 0 & 0 \\ 0 & 0 & \eta & -(\mu+\sigma+\gamma+\rho) & \phi(1+z) & 0 & 0 & 0 \\ 0 & \beta & 0 & 0 & -[\phi(1+z)+\lambda+\sigma+\mu] & 0 & 0 & 0 \\ 0 & 0 & 0 & \gamma & 0 & -(\omega+\mu+\sigma) & 0 & 0 \\ 0 & 0 & 0 & \rho & \lambda & \omega & -\mu & 0 \end{vmatrix} \quad (15)$$

Now the Jacobian matrix (J) at the DFE (ϵ_0) is given by

$$J_0 = \begin{vmatrix} -\mu & 0 & 0 & 0 & 0 & 0 & 0 & 0 \\ 0 & -[\theta(1+y)+\beta+\mu] & 0 & 0 & 0 & 0 & 0 & 0 \\ 0 & \theta(1+y) & -(\eta+\mu) & 0 & 0 & 0 & 0 & 0 \\ 0 & 0 & \eta & -(\mu+\sigma+\gamma+\rho) & \phi(1+z) & 0 & 0 & 0 \\ 0 & \beta & 0 & 0 & -[\phi(1+z)+\lambda+\sigma+\mu] & 0 & 0 & 0 \\ 0 & 0 & 0 & \gamma & 0 & -(\omega+\mu+\sigma) & 0 & 0 \\ 0 & 0 & 0 & \rho & \lambda & \omega & -\mu & 0 \end{vmatrix}$$

Using the principle of m-matrix, the Eigen values of J_0 have negative real part which are given by

$$\lambda_1 = -\mu \quad \lambda_2 = -[\theta(1+y)+\beta+\mu] \quad \lambda_3 = -(\eta+\mu) \quad \lambda_4 = -(\mu+\sigma+\gamma+\rho) \quad \lambda_5 = -[\phi(1+z)A+\lambda+\sigma+\mu] \quad \lambda_6 = -(\omega+\mu+\sigma) \quad \lambda_7 = -\mu$$

Since the Eigen values of the Jacobian matrix of model (1) at the disease free equilibrium have negative real parts, we therefore conclude that the disease free equilibrium state of the COVID-19 model is locally asymptotically stable. This means, a little variation of this present state does not cause any change in the system.

Epidemiologically, this result implies that the disease will be eradicated with respect to the initial condition (population) considered.

3.5 Local stability analysis of the endemic equilibrium point

Using the method developed by [23], the endemic equilibrium point of a model is locally asymptotically stable provided the determinant of the Jacobian matrix (15) is greater than zero and the trace of the same matrix is less than zero both expressed at the endemic disease equilibrium point (ϵ_1).

Now, trace is defined as the sum of the major diagonal element of the Jacobian matrix(15);

From the Jacobian matrix expressed in equation (15), we have that

Trace of the Jacobian matrix is evaluated as:

$$J = -[(\alpha(1-x) + \mu) + (\theta(1+y) + \beta + \mu) + (\eta + \mu) + (\mu + \sigma + \gamma + \rho) + (\phi(1+z) + \lambda + \sigma + \mu + \omega + \mu + \sigma + \mu)]$$

Therefore the Trace of the Jacobian matrix (15) is given as:

$$J = -[\alpha(1-x) + \theta(1+y) + \phi(1+z) + \beta + \eta + \gamma + \rho + \omega + \lambda + 3\sigma + \mu] \quad (16)$$

To find the determinant of Jacobian matrix (15), we use maple 2015 and result shows that the determinant of the matrix expressed in equation (2) is given by:

$$J = [(\alpha(1-x) + \mu)(\theta(1+y) + \beta + \mu)(\eta + \mu)(\mu + \sigma + \gamma + \rho)(\phi(1+z) + \lambda + \sigma + \mu)(\omega + \mu + \sigma)\mu] \quad (17)$$

From equation (16) and (17), we have that, Trace of $J < 0$ and the Determinant of $J > 0$

Since the trace of $J < 0$ and the determinant of $J > 0$, both at endemic equilibrium, we conclude that the endemic disease equilibrium is asymptotically stable.

This implies that a little variation of the present state does not cause any change in the system.

3.6 Sensitivity analysis of COVID 19 model

Sensitivity analysis shows how sensitive a model or system is to changes in the value of the parameter of the model and the variation in the structure of the model. It enables us to have confidence in a model by studying the probabilities that are often associated with parameters in such models.

Sensitivity analysis of COVID-19 model is conducted to know which parameters should be targeted by control intervention strategies.

Mathematically, the normalized forward sensitivity index of parameters (α) that depends on differentiable (R_0) is defined or expressed as:

$$\chi_{\alpha}^{R_0} = \frac{\partial R_0}{\partial \alpha} \times \frac{\alpha}{R_0} \quad (18)$$

The sensitivity index of the remaining parameters that depend on the differentiable quantity (R_0) can be expressed or defined just the same way as equation (18). Using maple 2015, we got that:

$$\begin{aligned} \chi_{\theta}^{R_0} &= \theta \{ k_7(\eta + \mu)(\phi(1+z) + \gamma + \sigma + \mu)(\omega + \mu + \sigma) \quad k_9(1-x) + \alpha_2(1+y)k_7 \\ &[\phi(1+z) + \lambda + \sigma + \mu)(\omega + \mu + \sigma)k_9(1-x) + \alpha_3\eta(\eta + \mu)(\phi(1+z) + \lambda + \sigma + \mu)(\omega + \mu + \sigma) \\ &[k_6 - \phi\beta(\eta + \mu)(1+z)]k_9(1-x) - k_7(\eta + \mu)(\omega + \mu + \sigma)\alpha_4(1+y)k_9(1-x) + \alpha_5[k_8 - \gamma\phi\beta(\eta + \mu) \\ &(1+z)]k_7(\eta + \mu)(\phi(1+z) + \lambda + \sigma + \mu)k_9(1-x); K_9K_7(\eta + \mu)(\phi(1+z) + \lambda + \sigma + \mu)(\omega + \mu + \sigma) / \\ &k_7(\eta + \mu)(\phi(1+z) + \lambda + \sigma + \mu)(\omega + \mu + \sigma)\alpha_1k_9(1-x) + \alpha_2(1+y)k_7[\phi(1+z) + \lambda + \sigma + \omega) \\ &(\omega + \mu + \sigma)\alpha_1k_9(1-x) + \alpha_3\eta(\eta + \mu)(\phi(1+z) + \lambda + \sigma + \mu)(\omega + \mu + \sigma)[k_6 - \phi\beta(\eta + \mu)(1+z) \\ &= -0.6121132 \end{aligned}$$

$$\begin{aligned} \chi_{\phi}^{R_0} &= -\phi \{ K_7(\eta + \mu)((1+z) + \lambda + \sigma + \mu)(\omega + \mu + \sigma)\alpha_1K_9(1-x) + \alpha_2\theta(1+y) K_7 \\ &[(1+z) + (\lambda + \sigma + \mu)(\omega + \mu + \sigma)K_9(1-x) + \alpha_3\eta(\eta + \mu)(1+z) + \lambda + \sigma + \mu)(\omega + \mu + \sigma) \\ &[k_6 - \beta(\eta + \mu)(1+z)]k_9(1-x) - k_7(\eta + \mu)(\omega + \mu + \sigma)\alpha_4\theta(1+y)k_9(1-x) + \alpha_5[k_8 - \gamma\beta \\ &(\eta + \mu)(1+z)]k_7(\eta + \mu)((1+z) + \lambda + \sigma + \mu)k_9(1-x); k_9(\eta + \mu)(1+z) + \lambda + \sigma + \mu)(\omega + \mu + \sigma) / \\ &(\eta + \mu)(\theta(1+z) + \lambda + \sigma + \mu)(\omega + \mu + \sigma)\alpha_1k_9(1-x) + k_7(\eta + \mu)(\omega + \mu + \sigma)\alpha_4\theta(1+y)k_9(1-x) + \\ &\alpha_5[k_8 - \gamma\phi\beta(\eta + \mu)(1+z)]k_7(\eta + \mu)(\theta(1+z) + \lambda + \sigma + \mu)k_9(1-x). \\ &= -0.8231501 \end{aligned}$$

$$\begin{aligned} \chi_{\eta}^{R_0} &= -\eta \{ (\phi(1+z) + \gamma + \sigma + \mu)(\omega + \mu + \sigma)\alpha_1k_9(1-x) + \alpha_2(1+y)k\eta[\phi(1+z) + \\ &\gamma + \sigma + \mu)(\omega + \mu + \sigma)k_9(1-x) + \alpha_3(\eta + \mu)\theta(1+z) + \lambda + \sigma + \mu)(\omega + \mu + \sigma) \\ &[k_6 - \theta\beta(\eta + \mu)(1+z)] - k_7(\omega + \mu + \sigma)\alpha_4(1+y)k_9(1-x) + \alpha_5[k_8 - \gamma\phi\beta\mu(1+z)] \\ &k_7\mu\phi(1+z) + \gamma + \sigma + \mu)k_9(1-x); k_9k_7(\eta + \mu)(\theta(1+z) + \lambda + \sigma + \mu) / k_7(\theta(1+z) \\ &+ \lambda + \sigma + \mu)(\omega + \mu + \sigma)\alpha_1k_9(1-x) + \alpha_2(1+y)k_7[\phi(1+z) + \lambda + \sigma + \mu)\alpha_1k_9(1-x) + \\ &\alpha_3(\eta + \mu)(\phi(1+z) + \lambda + \sigma + \mu) + \alpha_4\theta(1+y)k_9(1+x) + \alpha_5[k_8 - \gamma\phi\beta(1+z)\mu]k_7(\eta + \mu) \\ &(\phi(1+z) + \lambda + \sigma + \mu)k_9(1-x). \\ &= -0.3241120 \end{aligned}$$

$$\begin{aligned} \chi_{\beta}^{R_0} &= \beta \{ k_7(\eta + \mu)(\phi(1+z) + (\lambda + \sigma + \mu)(\omega + \mu + \sigma)\alpha k_9(1-x) + (\alpha_2(1+y)k\eta + \lambda + \sigma + \mu) \\ &(\omega + \mu + \sigma)k_9(1-x) + \alpha_3\eta(\eta + \mu)(\phi(1+z) + \lambda + \sigma + \mu)(\omega + \mu + \sigma)[k_6 - \phi(\eta + \mu)(1+z)] \\ &k_9(1-x) - k_7(\eta + \mu)(\omega + \mu + \sigma)\alpha_4(1+y)k_9(1-x) + \alpha_5[k_8 - \gamma\phi(\eta + \mu)(\phi(1+z)]k_7(\eta + \mu) \\ &(\phi(1+z) + \lambda + \sigma + \mu)k_9(1-x); k_9k_9(\eta + \mu)(\phi(1+z) + \lambda + \sigma + \mu)(\omega + \mu + \sigma) / k_7(\phi(1+z) + \\ &\lambda + \sigma + \mu)(\omega + \mu + \sigma)\alpha_1k_9(1+x) + \alpha_2(1+y)(\phi(1+z) + \lambda + \sigma + \mu)(\omega + \mu + \sigma)\alpha_1k_9(1-x) + \\ &\alpha_2(1+y)(\phi(1+z) + \lambda + \sigma + \mu)(\omega + \mu + \sigma)\alpha_1k_9(1-x) + \alpha_3\eta(\eta + \mu)(\phi(1+z) + \lambda + \sigma + \mu) \\ &(\omega + \mu + \sigma)[k_6 - \phi(\eta + \mu)(1+z)] \\ &= 0.8341261 \end{aligned}$$

$$\begin{aligned} \chi_{\gamma}^{R_0} &= -\gamma\{k_7(\eta + \mu)(\phi(1+z) + \lambda + \sigma + \mu)(\omega + \mu + \sigma)\alpha_1 k_9(1-x) + \alpha_3 \eta(\eta + \mu)(\phi(1+z) + \lambda + \sigma + \mu) + \\ &(\omega + \mu + \sigma)[k_6 - \phi\beta(\eta + \mu)(1+z)]k_9(1-x) - k_7(\eta + \mu)(\omega + \mu + \sigma)\alpha_4(1+y)k_9(1-x) + \alpha_5 \\ &[k_8 - \phi\beta(\eta + \mu)(1+z)]k_7(\eta + \mu)(\phi(1+z) + \lambda + \sigma + \mu)k_9(1-x)\}k_9 k_7(\eta + \mu)(\phi(1+z) + \lambda + \sigma + \mu) \\ &(\omega + \mu + \sigma) / k_7(\eta + \mu)(\phi(1+z) + \lambda + \sigma + \mu)(\omega + \mu + \sigma)\alpha_1 k_9(a-x) + \alpha_2(1+y)k_7[\phi(1+z) \\ &+ \lambda + \sigma + \mu](\omega + \mu + \sigma)\alpha_1 k_9(1-x) + \alpha_3 \eta(\eta + \mu)(\phi(1+z) + \lambda + \sigma + \mu)(\omega + \mu + \sigma)[k_6 - \phi\beta \\ &(\eta + \mu)(1+z) - k_7(\eta + \mu)(\omega + \mu + \sigma)\alpha_4 \theta(1+y)k_9(1-x)]. \\ &= -0.52411130 \end{aligned}$$

$$\begin{aligned} \chi_{\lambda}^{R_0} &= \lambda\{k_7(\eta + \mu)(\phi(1+z) + \sigma + \mu)(\omega + \mu + \sigma)\alpha_1 k_9(1-x) + \alpha_2(1+y)k_7[\phi(1+z) + \sigma + \mu] \\ &(\omega + \mu + \sigma)k_9(1-x) + \alpha_3 \eta(\eta + \mu)(\phi(1+z) + \sigma + \mu)(\omega + \mu + \sigma)[k_6 - \phi\beta(\eta + \mu)(1+z)] \\ &k_9(1-x) - k_7(\eta + \mu)(\omega + \mu + \sigma)\alpha_4(1+y)k_9(1-x) + \alpha_5[k_8 - \gamma\phi\beta(\eta + \mu)(1+z)]k_7(\eta + \mu) \\ &(\phi(1+z) + \sigma + \mu)k_9(1-x)\}k_9 k_7(\eta + \mu) / (\eta + \mu)(\phi(1+z) + \sigma + \mu)(\omega + \mu + \sigma)\alpha_1 k_9(1-x) + \\ &\alpha_2(1+y)k_7[\phi(1+z) + \sigma + \mu](\omega + \mu + \sigma)\alpha_1 k_9(1-x) + \alpha_5 \phi\beta(\eta + \mu)(1+z)k_7(\eta + \mu)(\phi(1+z) + \\ &\sigma + \mu)k_9(1-x)]. \\ &= 0.0082113 \end{aligned}$$

$$\begin{aligned} \chi_{\omega}^{R_0} &= \omega\{k_7(\eta + \mu)(\phi(1+z) + \lambda + \sigma + \mu)(\mu + \sigma)\alpha_1 k_9(1-x) + \alpha_2(1+y)k_7[\phi(1+z) + \lambda + \sigma + \mu] \\ &(\mu + \sigma)k_9(1-x) + \alpha_3 \eta(\eta + \mu)(\phi(1+z) + \sigma + \lambda + \mu)[k_6 - \phi\beta(\eta + \mu)(1+z)]k_9(1-x)k_7(\eta + \mu)(\mu + \sigma) \\ &\alpha_4(1+y)k_9(1-x) + \alpha_5[k_8 \gamma\phi\beta(\eta + \mu)(1+z)]k_7(\eta + \mu)(\phi(1+z) + \sigma + \mu)k_9(1-x)\} / (\eta + \mu)(\phi(1+z) + \\ &\lambda + \sigma + \mu)(\mu + \sigma)\alpha_1 k_9(1-x) + \alpha_2(1+y)k_7\eta. \\ &= 0.0583215 \end{aligned}$$

$$\begin{aligned} \chi_{\alpha_1}^{R_0} &= \alpha_1\{k_7(\eta + \mu)(\phi(1+z) + \lambda + \sigma + \mu)(\omega + \mu + \sigma)k_9(1-x) + \alpha_2(1+y)k_7[\phi(1+z) + \\ &\lambda + \sigma + \mu](\omega + \mu + \sigma)k_9(1-x) + \alpha_3 \eta(\eta + \mu)(\phi(1+z) + \lambda + \sigma + \mu)(\omega + \mu + \sigma)[k_6 - \phi\beta \\ &(\eta + \mu)(1+z)]k_9(1-x) - k_7(\eta + \mu)(\omega + \mu + \sigma)\alpha_4(1+y)k_9(1-x) + \alpha_5[k_8 - \gamma\phi\beta(\eta + \mu)(1+z)] \\ &k_7(\eta + \mu)(\phi(1+z) + \lambda + \sigma + \mu)k_9(1-x)\}k_9 k_7(\eta + \mu)(\phi(1+z) + \lambda + \sigma + \mu)(\omega + \mu + \sigma) / k_7 \\ &(\eta + \mu)(\phi(1+z) + \lambda + \sigma + \mu)(\omega + \mu + \sigma)k_9(1-x). \\ &= 0.6321110 \end{aligned}$$

$$\begin{aligned} \chi_{\alpha_4}^{R_0} &= \alpha_4\{k_7(\eta + \mu)(\phi(1+z) + \lambda + \sigma + \mu)(\omega + \mu + \sigma)\alpha_1 k_9(1-x) + \alpha_2(1+y)k_7[\phi(1+z) + \\ &\lambda + \sigma + \mu](\omega + \mu + \sigma)k_9(1-x) + \alpha_3 \eta(\eta + \mu)(\phi(1+z) + \lambda + \sigma + \mu)(\omega + \mu + \sigma)[k_6 - \phi\beta(\eta + \mu) \\ &(1+z)]k_9(1-x) - k_7(\eta + \mu)(\phi(1+z) + \lambda + \sigma + \mu)k_9(1-x)\}k_9 k_7(\eta + \mu)(\phi(1+z) + \lambda + \sigma + \mu) \\ &(\omega + \mu + \sigma) / [k_6 - \phi\beta(\eta + \mu)(1+z)]k_9(1-x) - k_7(\eta + \mu)(\omega + \mu + \sigma)\theta(1+y)k_9(1-x). \\ &= 0.93101117 \end{aligned}$$

$$\begin{aligned} \chi_{\alpha_5}^{R_0} &= \alpha_5 \{ k_7(\eta + \mu)(\phi(1+z) + \lambda + \sigma + \mu)(\omega + \mu + \sigma)\alpha_1 k_9(1-x) + \alpha_2(1+y)k_7[\phi(1+z) + \\ &\lambda + \sigma + \mu)(\omega + \mu + \sigma)k_9(1-x) + \alpha_3\eta(\eta + \mu)(\phi(1+z) + \lambda + \sigma + \mu)(\omega + \mu + \sigma)[k_6 - \phi\beta \\ &(\eta + \mu(1+z))]k_9(1-x) - k_7(\eta + \mu)(\omega + \mu + \sigma)\alpha_4(1+y)k_9(1-x) + [k_8 - \gamma\phi\beta(\eta + \mu)(1+z)] \\ &k_7(\eta + \mu)(\phi(1+z) + \lambda + \sigma + \mu)k_9(1-x) \} / [k_8 - \gamma\phi\beta(\eta + \mu)(1+z)]k_7(\eta + \mu)(\phi(1+z) + \sigma + \mu) \\ &k_9(1-x) \} / (\eta + \mu)(\phi(1+z) + \lambda + \sigma + \mu)(\mu + \sigma)\alpha_1 k_9(1-x) + \alpha_2(1+y)k\eta. \\ &= 0.065321112 \end{aligned}$$

Table 3. Numerical value of the sensitivity index

S/N	Parameter	Sensitivity Index	Parameter Values
1.	θ	-0.6121132	0.6
2.	ϕ	-0.8231501	0.7
3.	η	-0.3241120	0.7
4.	β	0.8341261	0.5
5.	γ	-0.5241130	0.6
6.	ω	0.0082113	0.0003
7.	α_1	0.0583215	0.6
8.	α_4	0.6321110	0.45
9.	α_5	0.93101117	0.60
10.		0.65321112	0.50

Result of the sensitivity analysis shows that, parameters with positive values increase the endemicity of the COVID-19 but the parameters with negative values decrease the endemicity of the COVID-19 pandemic.

In other words increasing the parameter values of those with negative index will reduce the basic reproduction number (R_0) of the COVID-19 and as such reduce the disease from the population. A reduction in the parameter values of those with positive index as shown in the Table (3) will also reduce the basic reproduction number (R_0) of the disease and this will also help in reducing the disease from the population.

4 Numerical Simulation

We presented the numerical simulation of the model (1) using Matlab ode15s solver. Parameter values used are presented in Table (4) below: Simulation results are presented in Fig. (2), Fig. (3) and Fig. (4) respectively.

Table 4. Numerical value of the sensitivity index

S/N	Value/Parameter	Values	Source	
1	S	10000	Estimated	
2	E	5000	Estimated	
3	Q	1000	Estimated	
4	J	500	Estimated	
5	I	200	Estimated	
6		I_T	100	Estimated
7	R	60	Estimated	
8	θ	0.6	Estimated	
9	ϕ	0.7	Estimated	
10	η	0.7	Estimated	
11	β	0.5	Estimated	
12	γ	0.6	Estimated	
13	ω	0.6	Estimated	
14	α	0.7	Estimated	
15	ρ	0.0005	Estimated	
16	λ	0.0003	Estimated	
17	σ	0.05	Estimated	
18	μ	0.005	Estimated	
19	Λ	0.5	Estimated	
20	x	0.2	Estimated	
21	y	0.4	Estimated	
22	z	0.6	Estimated	

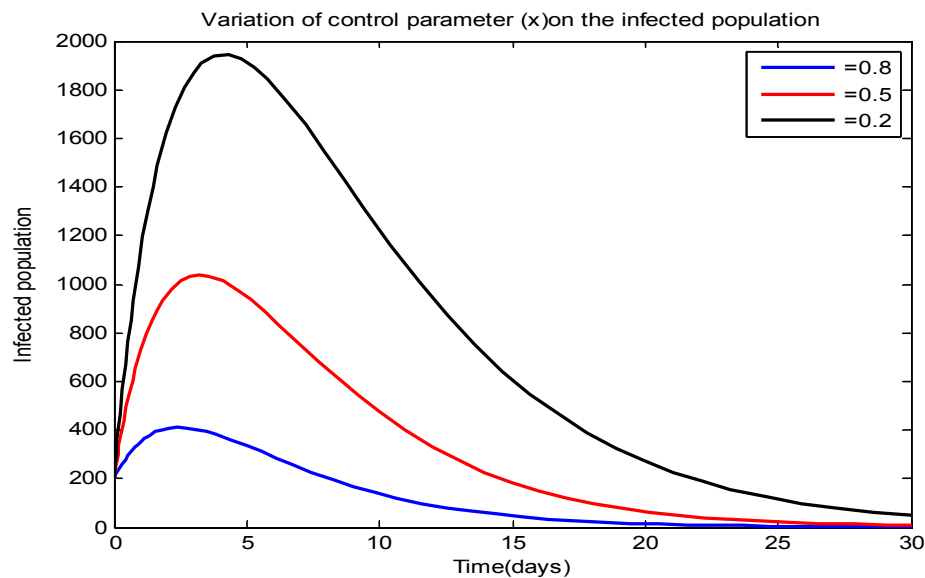

Fig. 2. Effect of increasing the enlightenment control measure for the susceptible individuals to observe social distance, regular washing of hands or the use of hand sanitizers and covering of mouth when coughing or sneezing

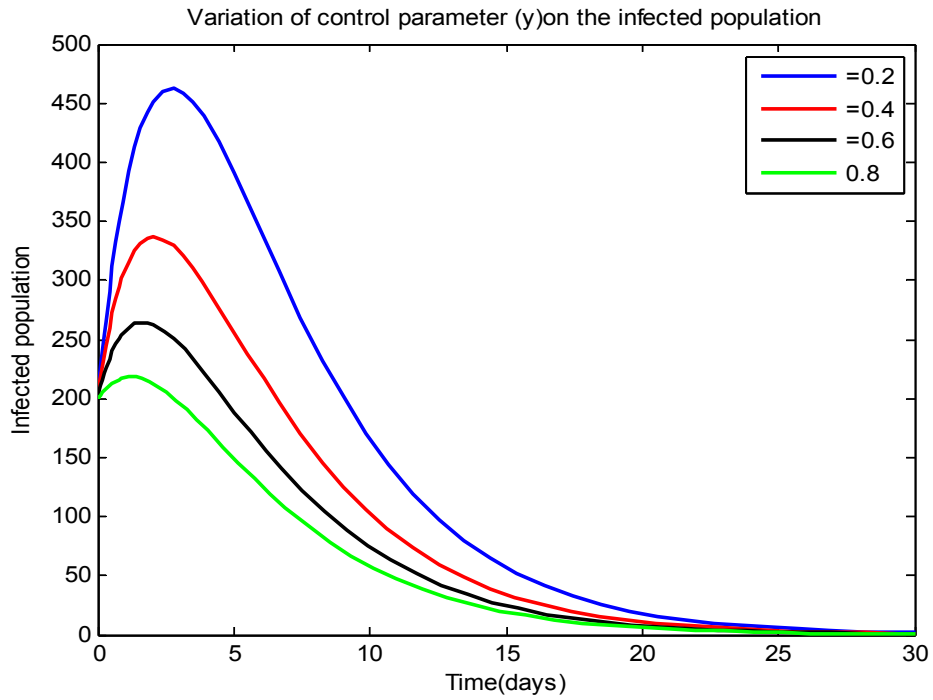

Fig. 3. Effect of increasing the enlightenment control measure to quarantine individuals suspected to have cases of COVID-19

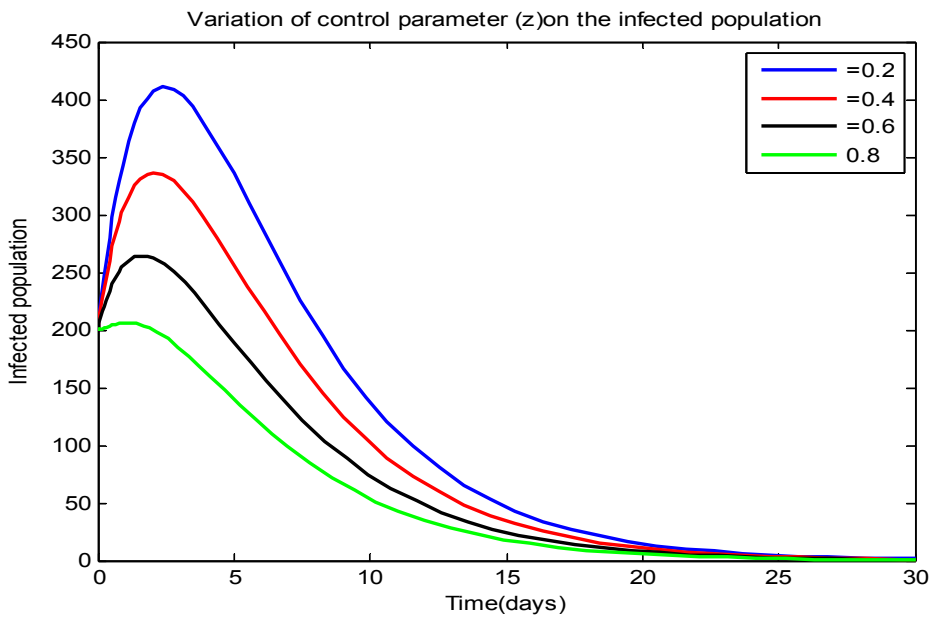

Fig. 4. Effect of increasing the enlightenment control measure to isolate individuals with cases of COVID-19

5 Discussion of Results and Conclusion

Fig. (2) shows the impact of increasing enlightenment control measure for the susceptible individuals to observe social distance, regular washing of hands or the use of hand sanitizers and covering of mouth when coughing or sneezing, increase in this rate reduces the population of the infected individuals. Similar dynamics is observed on the total infected population as depicted in Fig. (3) and Fig. (4) respectively, as increase in the rates at which unconfirmed and confirmed cases of COVID-19 are quarantined and isolated respectively reduces the population of the infected individuals.

Result from sensitivity analysis shows that the rate at which the exposed are quarantined (θ), the rate at which the infected are isolated (ϕ), the rate at which the quarantined are isolated (η), and the treatment rate (γ) should be targeted by the control intervention strategies as an increase in the parameter values of these parameters (θ, ϕ, η and γ) will reduce the basic reproduction number (R_0) of the COVID-19 and as such will reduce and even eliminate the disease from the population with time.

We therefore conclude that full compliance of individuals in observing social distance, the use of hand sanitizers and covering of mouth when coughing or sneezing eliminate the disease from a population with time. Similarly, quarantining the suspected cases of COVID-19, isolating the confirmed cases and increasing the rate at which supportive treatment is given to the infected individuals eliminate COVID-19 from a population.

Corona virus would be eliminated from a population if the above mentioned control strategies are strictly followed as prevention is better than cure.

Acknowledgement

The Authors are grateful to the handling Editors and the Reviewers for their constructive comments.

Competing Interests

Authors have declared that no competing interests exist.

References

- [1] "Coronavirus disease 2019" World Health Organization; 2020.
Retrieved 15th March, 2020.
- [2] "Novel Corona virus in China" World Health Organization; 2020.
Retrieved 19th April, 2020.
- [3] "Statement on the second meeting of the International Health Population (2005) emergency committee regarding the outbreak of Novel Corona virus" World Health Organization; 2020.
- [4] "Director-general opening remarks at the media briefing on Covid-19". World Health Organization; 2020.
Retrieved 11th March, 2020.

- [5] “Corona virus (Covid-19) global cases by the centre for systems science and engineering at Johns Hopkins University” Johns Hopkins CSSE; 2020.
Retrieved 14th April 2020.
- [6] “Corona Virus update (live)” World meter ncov2019 live; 2020.
- [7] “Global Covid19 case fatality rates” Centre for evidence-base medicine; 2020.
Retrieved 10th April 2020.
- [8] “Symptoms of Novel Corona virus (2019- ncov)” US centres for Disease Control and Prevention; 2020.
Retrieved 11th February, 2020.
- [9] “Interim clinical guidance for management of patients with confirmed Corona virus”. Centre for Disease Control and Prevention; 2020.
Retrieved,11th April, 2020.
- [10] “New Corona virus Stables for hours on Surfaces” National Instituted of Health (NIH); 2020.
Retrieved 24th March, 2020.
- [11] “Caring for yourself at home” Centres for disease control and prevention; 2020.
Retrieved 23rd March 2020.
- [12] “Questions and answers on Corona virus” World Health Organisation; 2020.
Retrieved 13th April, 2020.
- [13] “Corona Virus Disease 2019-transmission”. Centres for disease control and prevention; 2020.
Retrieved 23th March, 2020.
- [14] “World Health Organisation”. Laboratory testing for Corona virus Disease 2019 unsuspected human cases. Interim guidance “; 2020.
- [15] Science daily, “Computed Tomography (CT) best diagnosis for COVID-19; 2020.
Retrieved 14th March, 2020.
- [16] Azad AR. “FDA authorizes first corona virus antibody test” CNN; 2020.
Retrieved 6th April, 2020.
- [17] New York Times “A list of what is been Cancelled because of Corona Virus”; 2020.
Retrieved 11th April, 2020.
- [18] Wu JT, Leung K, Leung GM. “Forecasting the potential domestic and International Spread of the 2019-nCOV outbreak originating in Wuhan, China; a modelling study. Lancet. 2020;395:689-697
- [19] Read JM, Bridgen JRE, Cummings DAT, Ho A, Jewell CP. Novel Corona virus 2019-nCov: early estimation of epidemiological Parameters and epidemic predictions. MedRxiv; 2020.

- [20] Tang B, Wang X, Li Q, Bregazzi L, Tang S, Xiao Y. Estimation of the transmission risk of 2019-ncov and its implication for public health interventions. J. Clin. med. 2020;9:462-469.
- [21] Zhu H, Gao Q, Li M, Wang C, Feng Z, Wang P. Host and infectivity prediction of Wuhan 2019 novel Corona virus Using deep Learning Algorithm. bioRxiv; 2020.
- [22] Diekmann O, Heesterbeek JAP. Mathematical epidemiology of infectious disease. Wiley series in mathematical and computational biology. John Wiley & Sons. West Sussex, England; 2000.
- [23] Nthiri TK. Mathematical modelling of typhoid fever disease incorporating perfection against infection. British Journal of Mathematics & Computer Sciences. 2016;14(1):1-10.

© 2020 William et al.; This is an Open Access article distributed under the terms of the Creative Commons Attribution License (<http://creativecommons.org/licenses/by/4.0>), which permits unrestricted use, distribution, and reproduction in any medium, provided the original work is properly cited.

Peer-review history:

The peer review history for this paper can be accessed here (Please copy paste the total link in your browser address bar)

<http://www.sdiarticle4.com/review-history/63754>